

Quality Lighting™



HIGHMAST

DESIGN-5410-LD



Early uses of high mast lighting in America, 1896

High Mast lighting has been used for over one hundred years. Although the concept has remained remarkably unchanged, the design and operation of high mast systems has improved considerably.

Why Highmast Lighting?

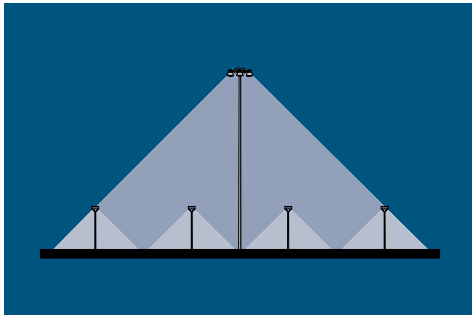

Why is highmast lighting so popular? Simply because it can light large areas with very few poles. Furthermore, highmast lighting provides less glare, better lighting uniformity, and the high mounting heights allow the poles to be located away from traffic areas, making them less prone to being damaged due to traffic accidents.

Why Quality Lighting?

Quality Lighting has a history in highmast lighting since 1965, bringing you many years of experience to satisfy your design and maintenance requirements.

Truck Stops
Prisons
Auto Lots
Storage Areas



Highmast's Future:

Everywhere you look, highmast lighting systems are at work providing even and uniform lighting. This future trend will continue to grow.

Quality Lighting's highmast systems are versatile:

As we all know, good lighting is important for all activities.

Public parking lots benefit by fewer poles and lower luminaire maintenance costs.

System Maintenance:

Maintenance procedures and costs are an important consider-

ation in the initial design of all high mast lighting systems. All specified components need to remain problem free between long maintenance intervals.

Luminaires are lowered to a height that service personnel can easily reach at ground level which reduces costs.

The system is easily energized at the ground level to insure correct luminaire maintenance.

High Performance Luminaire:

Quality Lighting offers the VA-25 highmast luminaire to complement our lowering device system. This luminaire boasts superior photometrics. Several lighting distributions and color options are available. See our VA-25 brochure for a complete review of this fixture.



VA-25 Luminaire

New For The 21st Century:

Quality Lighting has combined highmast area lighting with a security/surveillance camera system. Contact our factory for additional information about our CLD security camera.



Optional CLD Security Camera

Standard Lowering Device Features



Closed Position



Open Position

Guide Casting (BL)
(Bottom Latch System is Supplied with Safety Chain at Base of Pole)

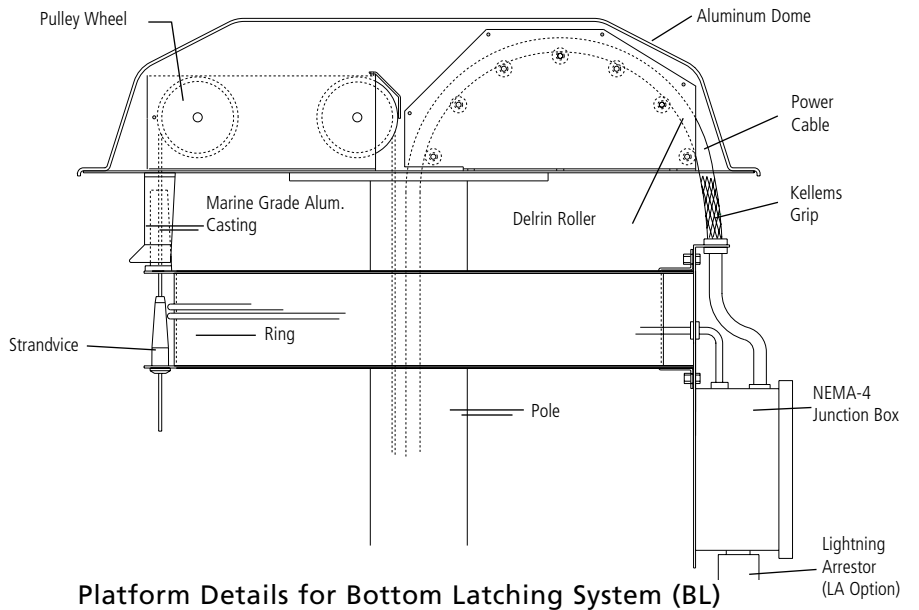

Platform Details for Bottom Latching System (BL)



Internal Bumper System

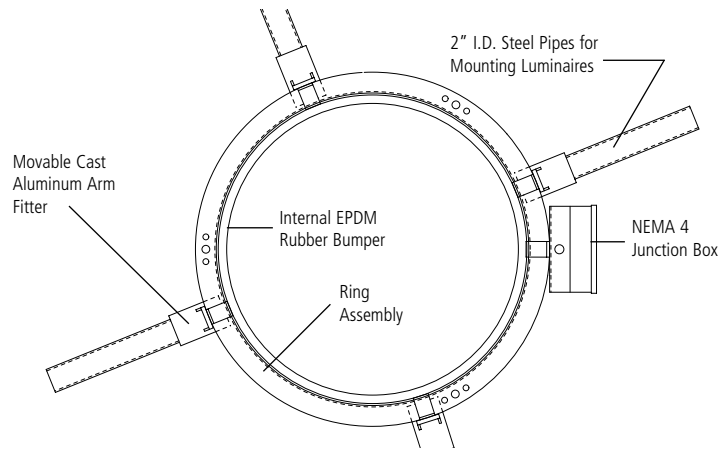

Plan View of Ring Assembly with Internal Bumper



External Portable Motor (HEM Option)

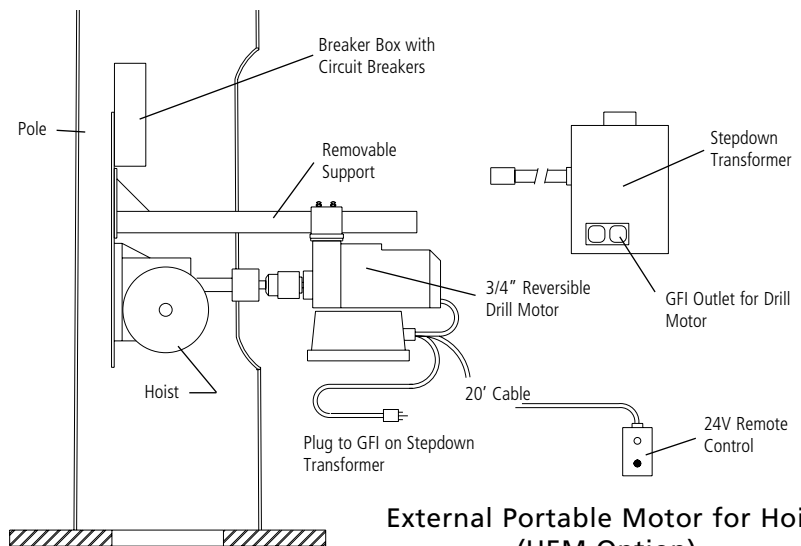

External Portable Motor for Hoist (HEM Option)

Options to Standard Lowering Device

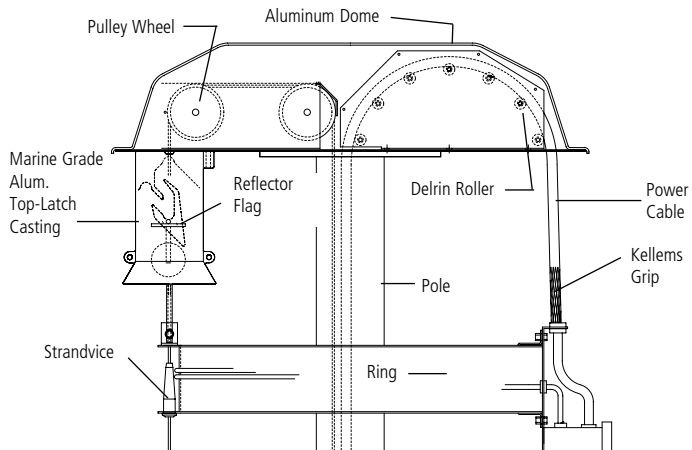

Platform Details for Top-Latching System (TL Option)



Latched Position Reflector Visible from Ground



Inside View of the Patented Top Latch Design

Top Latch (TL Option)

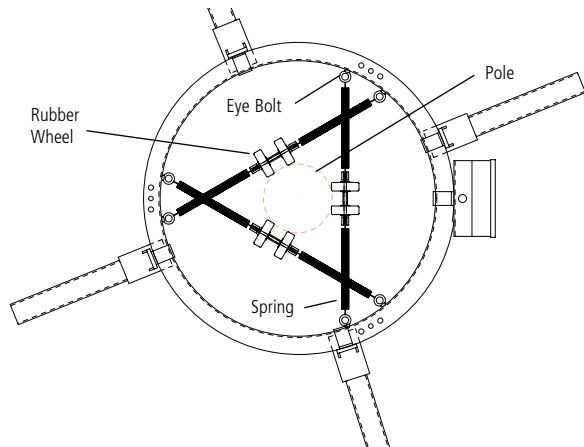

Plan View of Centering Springs (CS Option)



Centering Spring (CS Option) Patented Design

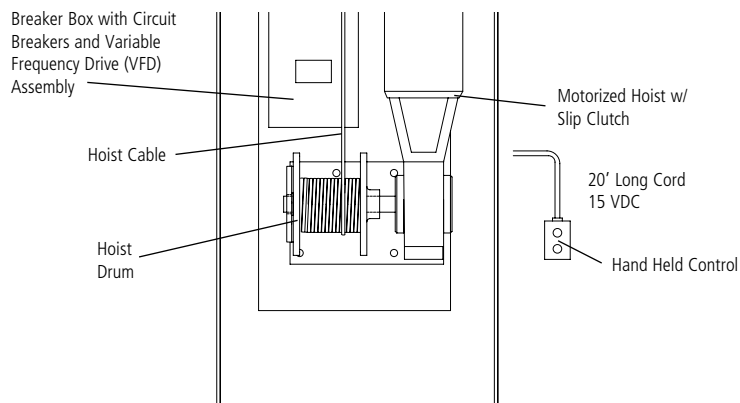

View of Internal Motorized Hoist (HIM Option)



Internal Motorized Hoist (HIM Option)

Standard Specifications



Guide Casting



Pulley support



Cast arm fitter
for pipe tenon



Transition
assembly



Electric cable pulley
support assembly



Portable motor mounted to pole (Option LD)



NEMA 4 junction box
(Mounted to ring)

Standard Head Frame Assembly: The headframe assembly consists of a platform plate, pulley support plates, reinforced nylon pulleys, bronze bushings, stainless steel clevis pins, cable keepers, aluminum guides, anodized aluminum cover, and stainless steel attaching hardware. Three marine grade cast aluminum (356T6) interlocking guides secure the ring assembly to the top platform. The headframe platform plate is manufactured from 11 gauge A36 steel, zinc-electroplated. The cable pulley support plates are fabricated from 11 gauge galvanized steel. Each lift cable is supported by two molybdenum disulfide reinforced nylon 5" diameter pulleys. The sheaves are grooved to carry the hoist cable. Oil impregnated sintered bronze bushings are pressed into the pulley hub and ride on 18-8 stainless steel 1/2" clevis pins. Keeper bars are used over cables to prevent cables from escaping grooves during installation and operation. The headframe assembly bolts directly to the high mast pole.

Luminaire Ring Assembly: The ring is fabricated to 6" x 2" x #10 gauge rolled steel per ASTM A-569, hot dipped galvanized per ASTM A-123 class B, with the appropriate number of luminaire mounting tenons of 2" steel pipe. The tenons are removable and the ring assembly is capable of mounting twelve fixtures. The inside of the ring is protected with a 1.5" deep extruded EPDM bumper. The pre-wired (PW) rings are wired with a power cord, Type SOW-A 3 conductor, 16 AWG, 90° C. All electrical cables attach to a fiberglass NEMA 4 weathertight junction box mounted to the ring through weathertight cord connectors. A weathertight twist lock test inlet is mounted to the junction box to permit testing of the luminaires while the ring is in the lowered position.

Transition Assembly: The transition assembly is cast from one piece 356-T6 high strength aluminum, 3/4" thick. The luminaire ring is supported by three stainless steel 19 x 7 non-rotating aircraft cables of 3/16" diameter manufactured per MIL W-83140. The lift cables pass up through the pole shaft, over the headframe pulleys, to the luminaire ring, where they are led through guides to a strandvice.

Top Cover: The entire headframe assembly is covered by a spun anodized aluminum cover, shaped specifically to prevent the accumulation of water.

Electrical Power Cord: The power cord is 4 conductor #8, 5 conductor #10 (Standard), or 5 conductor #8 type SOW-600 volts, 90°C EPDM insulated. The power cord is supported by seven rollers mounted between two galvanized steel supports. The power cord rides on rollers made from delrin resin the rollers provide positive electrical cable alignment. The rollers are mounted on .25" stainless steel clevis pins.

Standard Hoist (HEM): The lighting ring is lowered and raised by means of a drum hoist. The drum hoist has a load rating of 1,200 pounds at a full drum accumulation of 150 feet of 1/4 inch diameter 7x19 stainless steel cable. The drum hoist has a design factor of 3:1 based on minimum material tensile strength. The drum hoist is equipped with a fail safe load brake which is internal to the gearbox. The brake utilizes a one way clutch bearing mechanism such that the brake is automatically applied in the lowering direction and when the load is stopped. The gearing is a 32:1 single lead precision cut worm gear. The gearing is totally enclosed in a sealed oil bath. The gearbox is die cast of type 380 high tensile aluminum alloy and includes fill, breather, level and drain plugs. The drum is cast of type 356T6 high tensile aluminum alloy. All shafts turn on high efficiency bearings. The drum turns on radial ball bearings including a bearing on the outboard side of the drum. The mounting frame of the drum hoist is of A36 formed steel construction. The drum hoist has a simple self aligning bolt on interface to accept the portable motor. The portable motor includes a mechanical overload device to prevent overloading of the drum hoist or the rigging. The drum hoist system is of a modular design and can be upgraded in the field with bolt-on components such that it may be converted to accept a permanent motor and mechanical overload device.

Portable Power Unit (LD): The portable power unit incorporates the drive motor, torque limiter, drive shaft and electrical controls. The power unit is capable of being installed, operated and removed by one person. The torque limiter has automatic resetting capabilities and does not require adjustments after being set at the factory. The drill motor is controlled by a 24 volt reversing switch connected by a 20 foot remote cord. A 24 volt system is used to insure safety in wet conditions. Unit is provided with a weatherproof, enclosed step-down transformer to operate the 120V power unit. The 120V line cord from the drill is plugged into a GFI outlet mounted to the step-down transformer.

Circuit Breaker Box: A galvanized steel electrical box is mounted to the hoist plate which includes either a 2P or 3P circuit breaker based upon the specified voltage and electrical load.

Option Specifications

Top Latching (Option TL): The headframe includes three cast aluminum top latch assemblies which support the luminaire ring when the lowering system is in its locked, operating position. The latch assemblies are made of marine grade 356T6 high strength aluminum incorporating three stainless steel pins mounted on the ring assembly which engage the latch assembly. The stainless steel latch pins shall hinge to provide smooth latching when pole is arched by sunlight. The ring assembly will latch if the ring is 1" off level. The latch pin brackets contain no moving parts or springs and shall remove all loading from the lift and hoist cables. The latching and unlatching of each latch assembly shall be signalled by reflecting indicator flags visible from the ground. There is a minimum clearance between the ring and the bottom of the platform to prevent bird nests and the formation of ice from affecting the unlatching operation.

Bottom Latching (Option BL): A chain assembly is provided to anchor the transition assembly to an anchor bolt at the pole base. This option is provided as a safety feature when the luminaire ring is secured to the top platform of the pole.

Motorized Hoist (Option HIM):

Motor Specification: Motor shall be 1 HP TENV wired directly to a VFD motor controller programmed to a maximum speed of 550 rpm.. Motor and gearbox shall be designed to provide a fixture ring travel speed of 10'-15' per minute. The motor shall be mounted directly to the gearbox. The motor can be serviced or replaced through the handhole of the pole without removing the winch/gearbox by simply removing four bolts. This can be done in complete safety at any time during the raising and lowering procedure.

Clutch Specifications: A positive drive coupling that works on a spring-loaded convex pin and detent design, which reacts to overloads and provides accurate mechanical overload protection. Major components are designed from special polymer materials that are resistant to water, salts, mild acids, and most other pollutants. The unit will function in temperatures from -40° F to +180° F.

Winch/Gear Box (drum hoist) Specification: The lighting ring is lowered and raised by means of a drum hoist. The drum hoist has a load rating of 1,200 pounds at a full drum accumulation of 150 feet of 1/4-inch diameter cable. Gear Box shall consist of a 60:1 self-locking worm gear configuration enclosed in a sealed, cast housing and filled with a maintenance free synthetic lubricant, and shall be complete with an internal slip clutch locking device. Design shall be maintenance free. Output shaft shall be 1 1/8" and shall be rated for a static load of at least 2500 lbs. The winch shall have a drum diameter of 4" and shall have a capacity of 180ft. of 1/4" stainless steel cable. The drum turns on radial ball bearings including a bronze bushing on the outboard side of the drum. The drum hoist system is of a modular design permitting operation using a 1 hp TENV motor bolted to an integral cast motor mount with a gear reducer to control the output of the motor.

Motor Control: Motor control shall consist of a VFD controller capable of providing power to a 1 HP, 480V 3Phase motor. Motor shall run at a constant speed and shall be capable of reverse operation through the controller. The VFD shall permit raising and lowering without the use of a reversing AC magnetic contact type starter. The VFD shall also provide a maximum of 15-volt V.D.C. for the remote switch/pendant operation without the use of a step down transformer. A pendant control station shall consist of a 25' SO type cord with separate momentary contact pushbuttons for raising and lowering of the fixture ring and shall be mounted in a NEMA 4 box. The VFD shall be UL approved as a motor protection device for raising and lowering operations. Current limit to 180% with frequency foldback to prevent tripping. Input voltage shall be - (480v, 3phase),(480v, 1phase), (240v, 1phase), (277v, 1phase), (347v, 1phase) mounted in the circuit breaker box.

Centering Spring (Option CS): A set of three spring roller assemblies are mounted to the inside of the ring assembly. They are designed to prevent the ring from contacting the pole during the raising and lowering operation. Each assembly consists of two 3" dia. rubber wheels, two stainless steel springs, and stainless steel eye bolts. The assemblies have a stainless steel shaft to complete the design. The standard bumper is not used.

Aircraft Warning Lights (Option FAA): Aircraft warning lights are provided as single and twin systems. Also available for the twin lights is a transfer relay. With one light illuminated the other stands ready to switch on when failure occurs. The lights have 100w lamps and are energized when the highmast lights are operating. The 120V power is supplied by a stepdown transformer mounted near the junction box on the highmast ring. The lights are pipe mounted to the ring assembly which can be maintained at ground level.

Lightning Rod (Option LR): The lightning rod is rigidly mounted to the top platform. The rod is 1/2" diameter copper (36" long), with a nickel tip. There is a #1/0 copper cable attached at the base of the rod which is bolted to the top plate of the highmast pole.

Camera Lowering Device (Option CLD): Quality Lighting has combined highmast area lighting with a security/surveillance camera system mounted to the luminaire ring. Contact our factory for additional information about our CLD security camera systems.



Inside view of the optional top latch patented design (Option TL)



Internal motorized hoist assembly (Option HIM)



Detail view of the optional patented centering spring design (Option CS)



Optional FAA-2 aircraft warning lights



Optional CLD Security Camera

Ordering Information

Creating a Catalog Number for the Highmast Lowering Device

For each category in the table below, fill in the Catalog Number for each component or option desired.

Ordering Example:

5410-LD - 100 - 8A - TL - SS - 5C10 - V4 - HEM - FAA
1 2 3 4 5 6 7 8 9

1. System

5410-LD

2. System Height

60' 70' 80' 90' 100'
 110' 120' 130' 140' 150'

3. Fixtures Per Ring

3A 4A 5A 6A 7A
 8A 9A 10A 11A 12A

4. Latching

BL Bottom latching with safety chain TL Top latching

5. Hoist Cables

SS Stainless steel (std)

6. Power Cord

5C-10 5 conductor #10 (standard) 5C-8 5 conductor #8
 4C-8 4 conductor #8

7. Voltage / Phasing

V1 120V single phase V9 347V single phase
 V2 120/240V single phase V10 347/600V three phase
 V3 208V three phase V11 Special wiring
 V4 240/480V single phase
 V5 277V single phase
 V6 277/480V three phase
 V7 480V single phase
 V8 480V three phase

8. Hoist

HEM Hoist for portable motor HIM Hoist with internal motor

9. Options

PW Pre-wire headframe w/SO cord (16/3) type SOW-A 90° Standard
 FAA Single aircraft warning light
 FFA-2 Twin aircraft warning light
 FFA-2TR Twin aircraft warning light w/ transfer relay
 LD Portable hoist motor w/ step-down transformer (Required with HEM)
 LA Lightning arrester LR Lightning rod (36")
 CS Centering springs CLD Camera Lowering Device
Includes HIM internal motor hoist

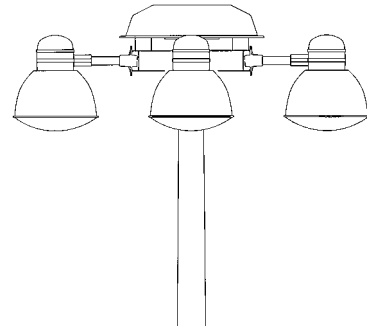

System Weight (excluding luminaires)

200 Lbs. (90.90 kgs)
Includes - Top Platform, Ring and Pipe Arms.

System E.P.A. (excluding luminaires)

4 Sq. Ft. (.38 M2)
Includes - Top Platform and Ring

Quality Lighting[™]

Quality Lighting is a Philips group brand

2930 South Fairview Street
Santa Ana, CA 92704
Phone (714) 371-2394 • FAX (714) 668-1107
Toll Free Phone (800) 545-1326
e-mail: sales@qualitylighting.com • www.qualitylighting.com
Specifications subject to change without notice. ©2007 Quality Lighting