

**Shopping Malls**  
**Walkways**  
**Building Entrances**  
**Parking Lots**



## Specifications

---



- HOUSING** The one-piece housing is cast of Type 319 aluminum. The integral cast aluminum fitter slips over 2" nominal pipe and allows for  $\pm 3^\circ$  leveling adjustment. The fixture is C-UL & UL listed "suitable for wet locations."
- GASKETING** A silicone-impregnated Dacron® gasket is used between the reflector and housing. Butyl-acrylic tape sealant is used between the lens and reflector.
- OPTICAL ASSEMBLY** The optical assembly consists of a one-piece 25" diameter spun aluminum reflector. The drop acrylic lens is fully gasketed to the reflector.
- ROTATABLE OPTICS** The reflector is easily rotated through 360° without the use of tools to facilitate aiming the main beam of non-symmetric distributions. Two stainless steel safety cables are provided to retain the reflector and lens when lamp replacement is necessary. Re-lamping is easily accomplished without the use of tools.
- BALLAST** All ballast components are readily-accessible from the top of the luminaire and are mounted on a single plate. CWA ballasts supplied for use with MH and HPS lamps provide  $\pm 5\%$  lamp power regulation with  $\pm 10\%$  variation from rated input voltage.
- FINISH** Electrostatically-applied textured baked enamel finish is applied over the aluminum ballast housing and top cap. The standard reflector finish is natural anodized aluminum.

<b>PROJECT</b>
<b>FIXTURE TYPE</b>
<b>CATALOG#</b>

Quality Lighting  
 2930 South Fairview Street  
 Santa Ana, CA 92704  
 Phone (714) 371-2394 • FAX (714) 668-1107 • Toll Free Phone (800) 545-1326  
 e-mail: sales@qualitylighting.com • www.qualitylighting.com  
 Specifications subject to change without notice. ©2007 Quality Lighting



**DISTRIBUTIONS**

- TYPE V** Symmetrical (Vert. Lamp)
- TYPE VS** Square (Vert. Lamp)
- TYPE VR** Rectangular (Vert. Lamp)

**ORDERING EXAMPLE** VAC-25-V-HPS-400-BK-120-T2-FD-IL45

DESIGN	DISTRIBUTION	HPS	MH/MHP	LAMP
VAC-25	V	400		ED-18
	V		400/450*	ED-37
	VS	400		ED-18
	VR	400		ED-18

MH = Std. Metal Halide  
 MHP = Pulse Start

\* Available only in Pulse Start

**REQUIRED CHOICES**

**FINISH**

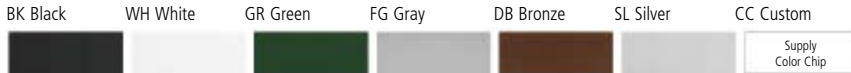

**VOLTAGES MOUNTING**

- 120 Slipfits Over 2-3/8" O.D. Tenon (Standard)
- 208
- 240
- 277
- 347
- 480

**OPTIONAL CHOICES**

**ELECTRICAL OPTIONS**

- FD Single Fusing 120V/277V
- FDD Double Fusing 480V
- FDFD Double Fusing 208V/240V
- FDC Single Fusing 347V

**LIGHT TRESPASS OPTIONS**

- IL45 Internal 45° Louver Shielding
- IL75 Internal 75° Louver Shielding

PCB Button Photo Control



IL45/IL75  
 Internal 45° or 75°  
 Louver Shielding

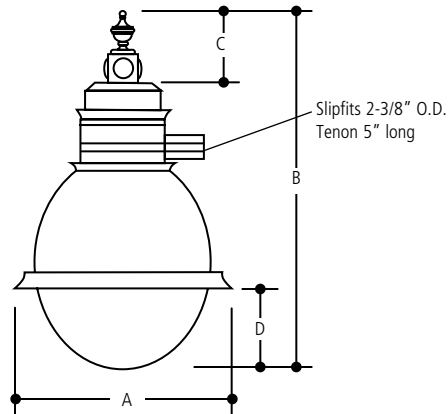

**DIMENSIONS**

- A 29" dia. (736.6 mm)
- B 45.60" (1158 mm)
- C 9.46" (240.28 mm)
- D 10.60" (266.7 mm)

**WEIGHT**

75 lbs. (34 kgs)

**EFFECTIVE PROJECTED**

**AREA (EPA)**

- 1 Fixture 2.8 sq. ft. (.26M2)
- 2 Fixtures 5.6 sq. ft. (.53M2)