

Parking Areas
Building Entrances
Pedestrian Walkways
Shopping Malls
Large Areas



Specifications



- HOUSING** Fixture shall be designed with one-piece heavy gauge spun aluminum housing. Dual mounting yoke shall be fabricated of 0.5" I.D. pipe. The fixture shall be C-UL & UL listed "suitable for wet locations."
- LENS DOOR** Heavy gauge aluminum lens door shall be hinged to the housing with a single stainless steel piano hinge and shall be secured with flush mounted vibration resistant captive screw type fasteners.
- LENS** The thermal and shock resistant flat tempered glass lens shall be sealed to the lens door and secured with retainer clips.
- GASKETING** The lens shall be gasketed to the lens door with extruded butyl acrylic sealant. The lens door shall be gasketed to the housing's internal reinforcement ring with silicone impregnated Dacron gasketing.
- INSTALLATION** Each Design SNDY shall be mounted on a dual yoke of 0.5" I.D. pipe, screwed to housing and welded to slipfitter. Tenon fitter shall mount to a round pole (see ordering information for details). The post-top fitter shall have a removable top cap.
- REFLECTOR** Luminaires shall be equipped with one of the following reflector systems: 1) Type VS - square distribution, vert. lamp; 2) Type F - forward throw distribution, horiz. lamp; 3) Type S - square distribution, horizontal lamp; 4) Type 2 - asymmetrical distribution, horiz. lamp; 5) Type 3 - asymmetrical distribution, horizontal lamp. All photometric data shall be certified by an independent testing facility.
- BALLAST** Core and coil ballast assembly is to be mounted on a fully unitized, quick disconnect ballast tray in the fixture housing. Ballasts are rated for -20°F. operation.
- FINISH** Polyester powder coat, electrostatically applied, which is preceded by a five step pre-treatment process including an iron phosphate priming stage for superior coating adhesion. This process meets or exceeds all ASTM testing requirements, including those for 1,000 - hour salt spray endurance testing.

PROJECT
FIXTURE TYPE
CATALOG#

Quality Lighting
 2930 South Fairview Street
 Santa Ana, CA 92704
 Phone (714) 371-2394 • FAX (714) 668-1107 • Toll Free Phone (800) 545-1326
 e-mail: sales@qualitylighting.com • www.qualitylighting.com
 Specifications subject to change without notice. ©2007 Quality Lighting

SNDY

DISTRIBUTIONS

- TYPE S Square (Horiz. Lamp)
- TYPE VS Square (Vertical Lamp)
- TYPE 2 Asymmetrical (Horiz. Lamp)
- TYPE 3 Asymmetrical (Horiz. Lamp)
- TYPE F Forward Throw (Horiz. Lamp)

ORDERING EXAMPLE SNDY-24-VS-HPS-150-DB-120-3"-FD-HSS

MH = Std. Metal Halide
 MHP = Pulse Start

DESIGN	DISTRIBUTION	HPS	MH/MHP	LAMP
SNDY-24	VS	100/150	100/150/175/200*	ED-17
SNDY-24	2	100/150 250/400	100/150/175/200*	ED-17
				ED-18
				ED-28
				ED-37
SNDY-24	3	100/150 250/400	100/150/175/200*	ED-17
				ED-18
				ED-28
				ED-37
SNDY-24	S	100/150 250/400	100/150/175/200*	ED-17
				ED-18
				ED-28
				ED-37
SNDY-24	F	100/150 250/400	100/150/175/200*	ED-17
				ED-18
				ED-28
				ED-37

* Available only in Pulse Start 100,150, 200 MHP = Pulse Start

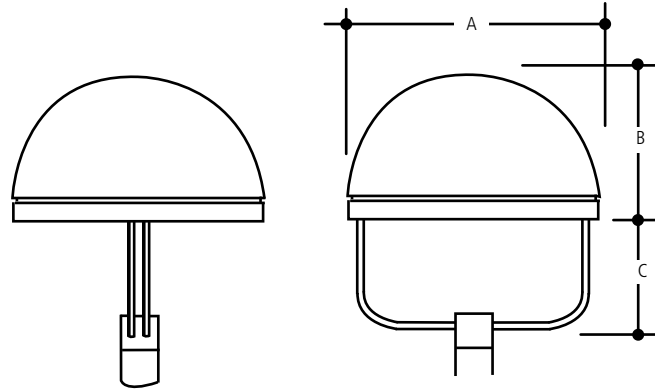

Note: See ordering information for pole size and mounting details.

DIMENSIONS

- A 24.00" (609.00 mm)
- B 15.00" (381.00 mm)
- C 11.00" (279.00 mm)

EFFECTIVE PROJECTED AREA (EPA)
 1.70 sq. ft. (.16M2)

WEIGHT
 60 lbs. (28.18 kgs)

REQUIRED CHOICES

FINISH



VOLTAGES MOUNTINGS

120	3"	Pole top (slips over pole)
208		Note: 3 set screws fasten fixture to pole
240		
277	4"	Pole top (internal slipfit) (standard)
347	5"	Pole top (internal slipfit)
480		Note: 4" & 5" poles must be drilled with 1/2" through holes for attachment - 3 @ 120° (1.5" from pole top)

OPTIONAL CHOICES

ELECTRICAL OPTIONS	OPTICAL OPTIONS	LIGHT TRESPASS OPTIONS
FD Single Fusing 120V/277V	LX Vandal Resistant Shield	HSS House Side Shield
FDD Double Fusing 480V		
DFD Double Fusing 208V/240V		
FDC Single Fusing 347V		
PCT Photo Cell and Receptacle		