

SPECIFICATIONS

- HOUSING** Each WFB bollard is constructed of 356 aluminum alloy castings. The head cap is mounted to the window housing. This cap is removable for servicing the lamp. The body tube section is manufactured from .125 thick aluminum wall tubing which is hot dipped galvanized (ASTM A-123) inside and out. All external threaded hardware shall be stainless steel and shall be of tamper proof design requiring a special tool for disassembly. The fixture is C-UL & UL listed "suitable for wet locations".
- LENS** The flat polycarbonate lens is sealed to the window housing. Lens is fully gasketed with weatherproof, durable silicone foam gasketing material.
- MOUNTING** Mounting shall use a cast aluminum base which is secured by three (3) 1/2" x 12" embedded anchor bolts. The bollard uses (3) 3/8" internal rods which extend from the top ring down to the base casting. This system ensures a secure vandal resistant mounting.
- BALLAST** All ballasts are CWA or HX-HPF type with power factor of 90%. Ballasts are rated for -20°F or -40°F operation. All ballasts are readily accessible, removable and insulated.
- FINISH** Polyester powder coat, electrostatically applied, which is preceded by a five step pre-treatment process including an iron phosphate priming stage for superior coating adhesion. This process meets or exceeds all ASTM testing requirements, including those for 1000 - hour salt spray endurance testing.

Quality Lighting™

Quality Lighting is a Philips group brand

2930 South Fairview Street
Santa Ana, CA 92704
Phone (714) 371-2394 • FAX (714) 668-1107
Toll Free Phone (800) 545-1326
e-mail: sales@qualitylighting.com • www.qualitylighting.com
Specifications subject to change without notice. ©2007 Quality Lighting

Quality Lighting™



ACCENT/PATHWAY

DESIGN-WFB-8



DISTRIBUTIONS

TYPE V Symmetrical (Vert. lamp)

Ordering Example WFB-8-V-HPS-70-BK-120-FD

DESIGN	DISTRIBUTION	HPS	MH/MHP	LAMP	MH = Std. Metal Halide MHP = Pulse Start
WFB-8	V	35/50	35/50	ED-17	
	V	70	70	ED-17	
	V	100	100	ED-17	

* Available only in Pulse Start 35,50,70,100 MHP = Pulse Start

REQUIRED CHOICES

VOLTAGES	FINISH						
	BK Black	WH White	GR Green	FG Gray	DB Bronze	SL Silver	CC Custom
120							Supply Color Chip
208							
240							
277							
347							

OPTIONAL CHOICES

ELECTRICAL OPTIONS

FD Single Fusing 120V/277V
 FDFD Double Fusing 208V/240V
 FDC Single Fusing 347V

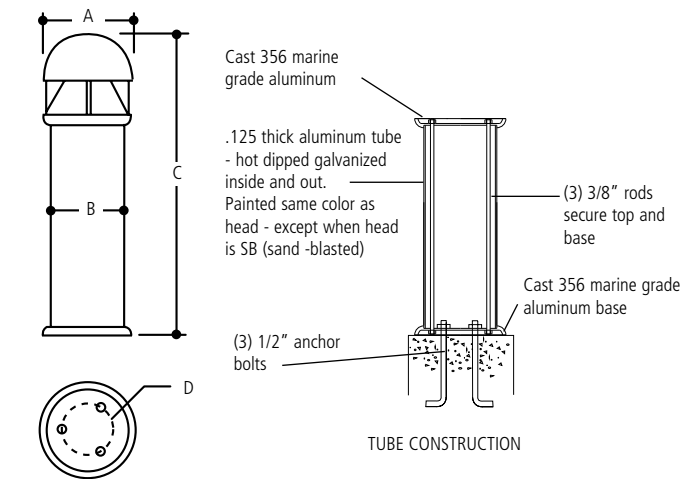

DIMENSIONS		WEIGHT	
A	10.00" Dia. (254 mm)	45.5 lbs.	(20.6 kgs)
B	8.00" (203 mm)		
C	33.50" Ht. (850.9 mm)		
	36.00 Ht. (914.4 mm)		
	42.00 Ht. (1066.8 mm)		

BOLT CIRCLE
 D 5.50" (139.70 mm)